

# GTD

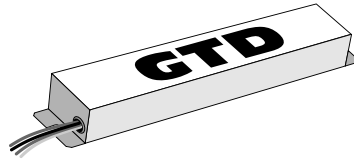

# bodine

## Installation Instructions

EMERGENCY LIGHTING CONTROL DEVICE



### **! IMPORTANT SAFEGUARDS !**

WHEN USING ELECTRICAL EQUIPMENT, BASIC SAFETY PRECAUTIONS SHOULD ALWAYS BE FOLLOWED, INCLUDING THE FOLLOWING:

## READ AND FOLLOW ALL SAFETY INSTRUCTIONS

1. This product is for use with generator or central inverter supplied fluorescent or LED fixtures. Make sure all connections are in accordance with the National Electrical Code and any local regulations.
2. To reduce the risk of electric shock, disconnect all power sources before servicing.
3. This product is for factory or field installation.
4. This product is suitable for damp locations where the ambient temperature is -20°C minimum, +65°C maximum. The product is also suitable for installation in sealed and gasketed fixtures. Product is not suitable for heated air outlets and wet or hazardous locations.
5. An unswitched, normal AC power source and a direct, unswitched connection to a generator or central inverter supplied emergency panel is required (120 or 277 VAC, 60 Hz).
6. Requires connection to an emergency source derived from a UL 1008 Listed transfer switch.
7. The use of accessory equipment not recommended by the manufacturer may cause an unsafe condition.
8. Do not use this product for other than intended use.
9. Servicing should be performed by qualified service personnel.

## SAVE THESE INSTRUCTIONS



**CAUTION:** THIS UNIT HAS MORE THAN ONE POWER SUPPLY CONNECTION POINT. TO REDUCE THE RISK OF ELECTRIC SHOCK, DISCONNECT ALL POWER SOURCES BEFORE INSTALLING OR SERVICING THIS UNIT.

### **SERVICE BY QUALIFIED PERSONNEL ONLY**

**NOTE:** BEFORE INSTALLING THIS DEVICE, MAKE SURE THAT THE NECESSARY BRANCH CIRCUIT WIRING IS AVAILABLE. AN UNSWITCHED SOURCE OF NORMAL POWER IS REQUIRED. A SEPARATE CONNECTION TO A GENERATOR-SUPPLIED (OR CENTRAL INVERTER SYSTEM-SUPPLIED) CIRCUIT MUST ALSO BE PROVIDED.

01/09/19

Bodine © 2018 Signify Holding. All rights reserved.

236 Mt. Pleasant Rd. • Collierville, TN USA 38017-2752 • Tech Support 888-263-4638 • Fax 901-853-5009 • www.bodine.com  
443529080234

# INSTALLATION

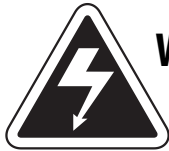

**WARNING:** Disconnect all power sources before installing or servicing this unit.  
The GTD is intended for an electrical load of ONE fixture only.

**NOTE:** BEFORE INSTALLING THIS DEVICE, MAKE SURE THAT THE NECESSARY BRANCH CIRCUIT WIRING IS AVAILABLE. AN UNSWITCHED SOURCE OF POWER ON THE SAME BRANCH CIRCUIT AS THE AC BALLAST IS REQUIRED. A SEPARATE CONNECTION TO A GENERATOR OR CENTRAL INVERTER SUPPLIED CIRCUIT MUST ALSO BE PROVIDED.

## INSTALLING THE GTD

- > FAMILIARIZE YOURSELF WITH THESE INSTRUCTIONS BEFORE BEGINNING INSTALLATION.
- > Disconnect AC power from the fixture. Remove the driver/ballast channel cover and install the GTD in the driver/ballast channel (see Illustration 1, 2 or 3).
- > Wire the GTD as shown in Illustration 4 or 5 whichever applies to your application.
- > After installation is complete, apply AC power to the fixture. Check AC driver/ballast operation to verify proper GTD installation.

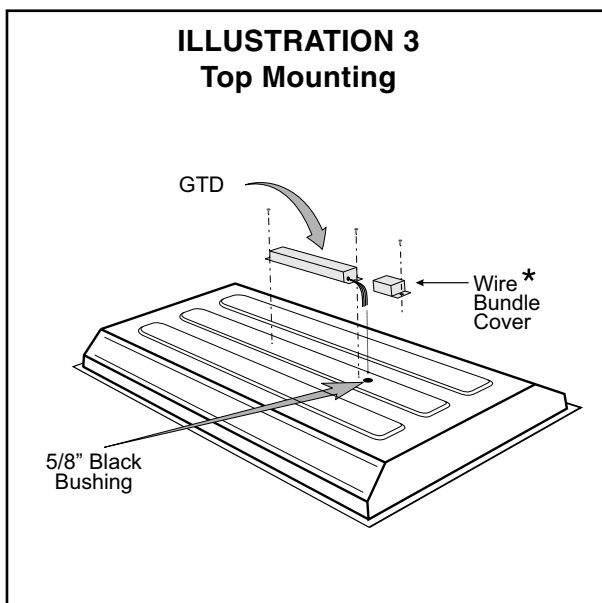
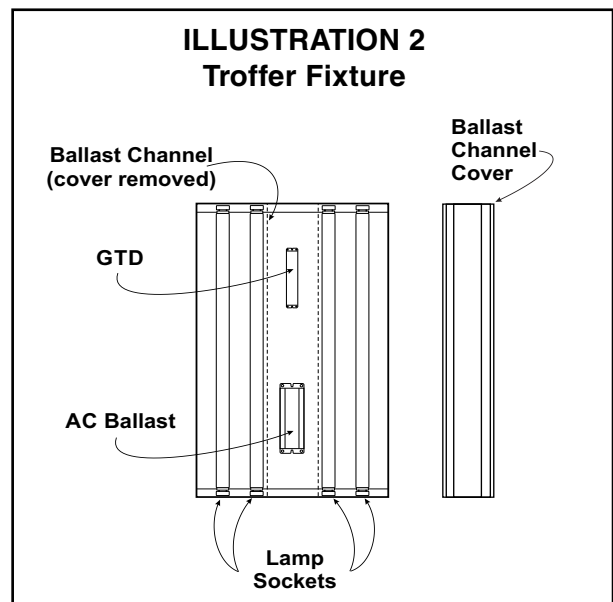
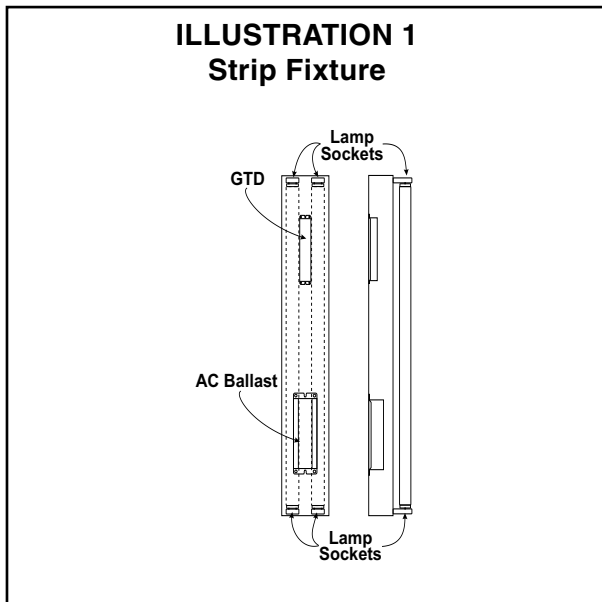

\* For installation on top of the fixture, wire bundle covers (RMC-60) may be required by state or local codes. These covers are available from the manufacturer as an accessory kit and must be ordered separately. Call your local distributor or the factory for complete information.

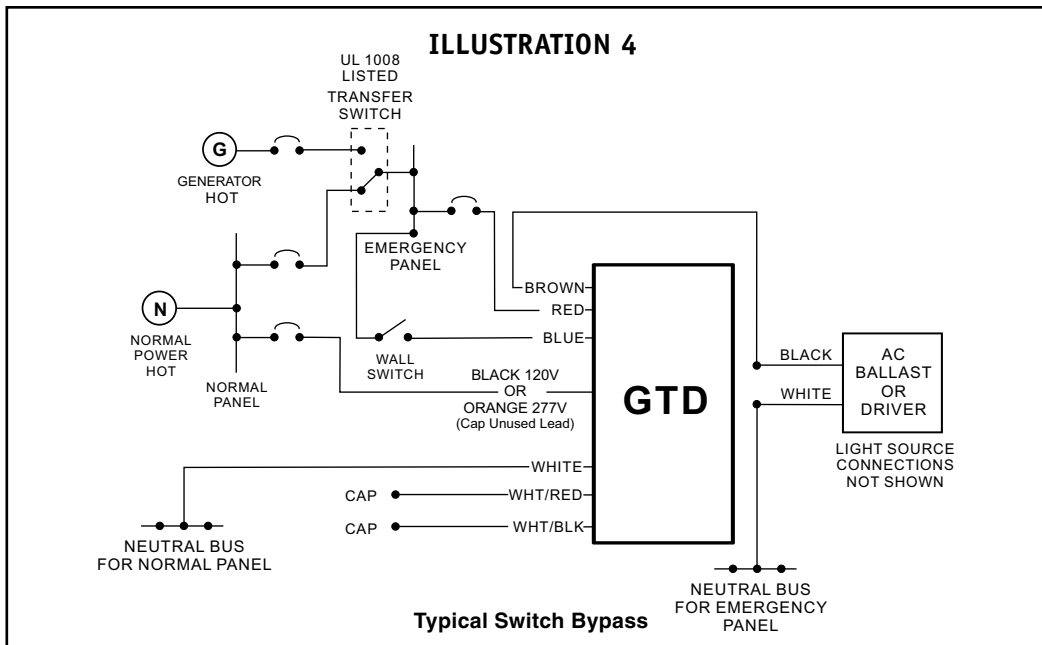

## OPERATION

The GTD uses an internal relay contact to control the AC power feeding the AC ballast or driver. When the generator (or central inverter) supplies AC power to the lighting fixture, the GTD bypasses the wall switch controlling the AC ballast or driver. This ensures the fixture lighting load will be energized during generator (or central inverter) operation regardless of switch position.

## MAINTENANCE

No routine maintenance is required to keep the GTD functional. However, it should be checked periodically to ensure that it is working properly.